

01H series



- Aluminum construction
- Top and bottom cover spaired plastic
- simple assembly
- Custom colors available
- Wide range of enclosure size
- Special assembly sevicees

Height/Width Chart

Exterior size			Interior size		Panel size		Panel mounting size	
Overall Height	HP	Overall width	Inside Height	Inside Width	Front panel blank size	Rear panel blank size	Front panel	Rear panel
H		L	h	l	B×A	D×C	m	n
100	42	234	80	218	212×97	211×97	90	90
100	63	341	80	325	319×97	318×97	90	90
100	84	448	80	432	426×97	425×97	90	90
110	42	234	90	218	212×107	211×107	100	100
110	63	341	90	325	319×107	318×107	100	100
110	84	448	90	432	426×107	425×107	100	100
120	42	234	100	218	212×117	211×117	110	110
120	63	341	100	325	319×117	318×117	110	110
120	84	448	100	432	426×117	425×117	110	110

Front view of enclosure

Front view (remove top cover and bottom cover)

Top view of enclosure

Top view (remove top cover and bottom cover)

Front panel

Rear panel

Depth Chart

Overall Depth	Interior Depth
T	t
180	164
240	224
300	284
320	304
360	344

Note: Custom depth available

Standard configuration

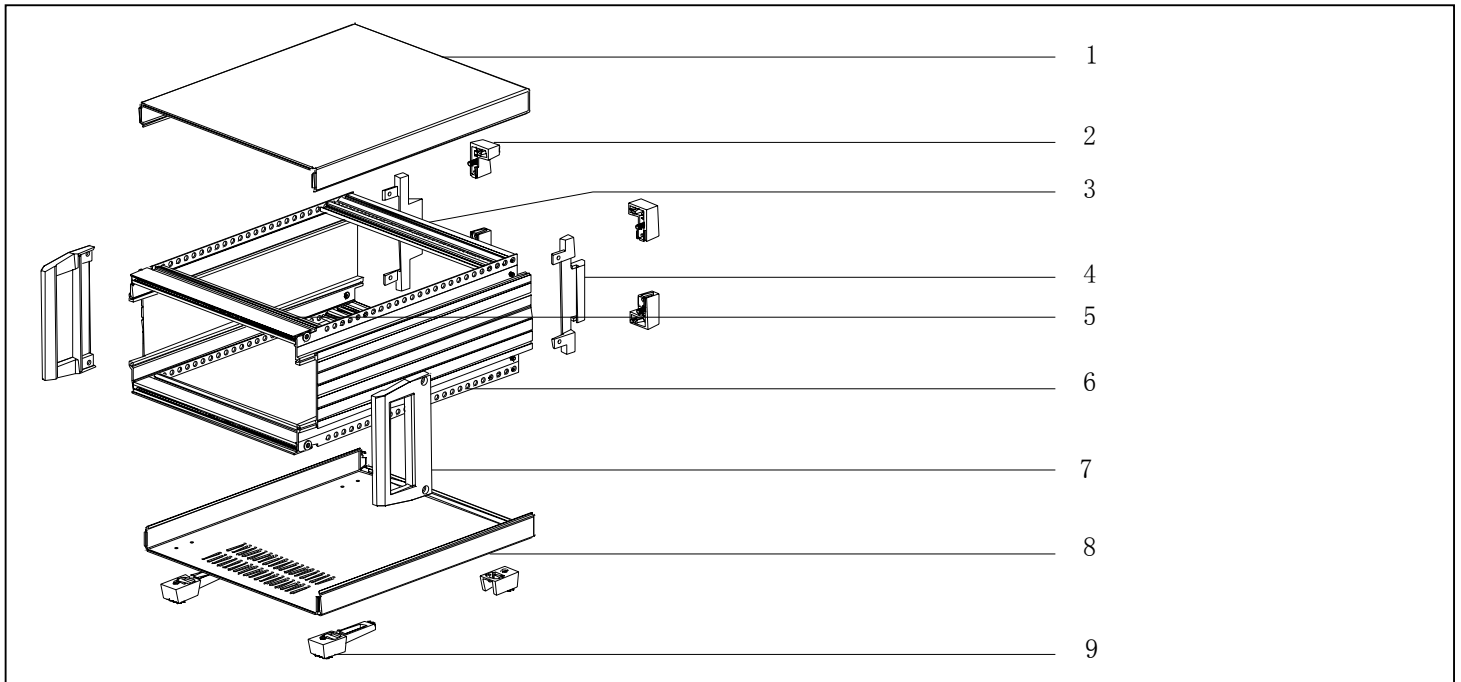

ITEM	PART	QTY	DESCRIPTION
1	Top cover	1	1mm Aluminium sheet,spary plastic
2	Rear foot	4	Moulded in PC,with rubber pad
3	Rear horizontal rail	2	Aluminium extrusion,pre-punched holes for card guide,clear anodized
4	Rear trim	2	Diecast aluminium,powder-coated
5	Front horizontal rail	2	Aluminium extrusion,pre-punched holes for card guide,powder-coated
6	Side plate	2	Aluminium extrusion,powder-coated
7	Handle	2	Diecast aluminium,powder-coated
8	Bottom cover	2	Aluminium sheet,spary plastic,with or without vent holes available
9	Bottom foot	4	Moulded in PC,with rubber pad,including 2 pcs of supporting foot

Extrusions

Front horizontal rail

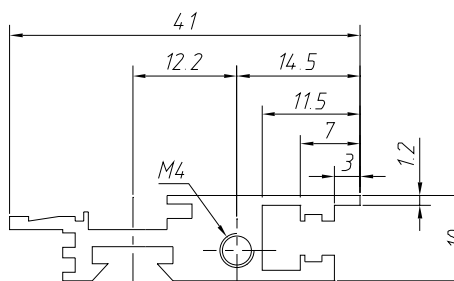

Length table			
HP	42	63	84
Length(mm)	218	325	432

- Material: Aluminum extrusion
- Powder-coated
- With or without pre-punched holes for card guide available

Rear horizontal rail

Length table			
HP	42	63	84
Length(mm)	218	325	432

- Material: Aluminum extrusion
- Spary plastic
- With or without pre-punched holes for card guide available

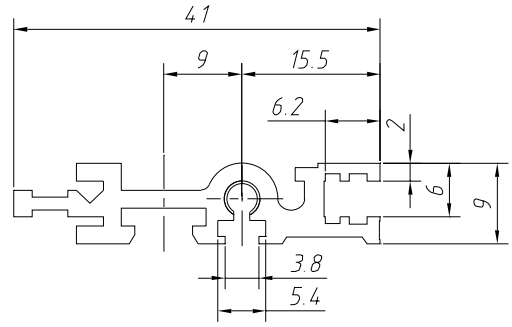

Side plate

- Material: Aluminum extrusion
- Optional depth according to case size
- Powder-coated
- Pre-punched holes for mounting side mounting plate or additional horizontal rail

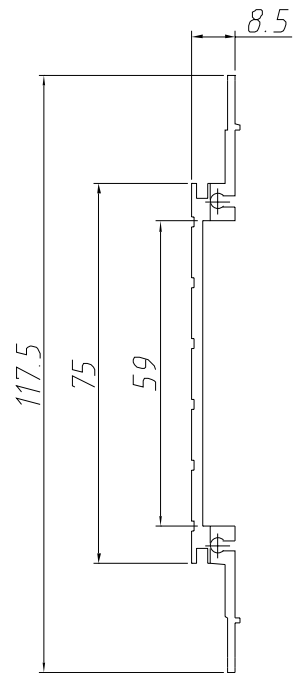
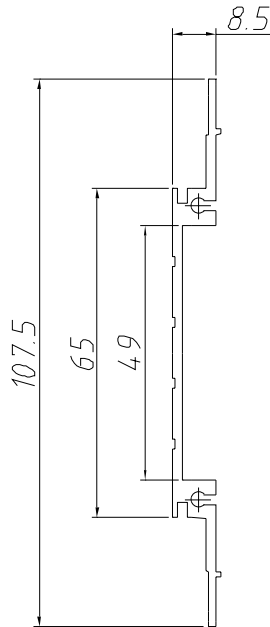
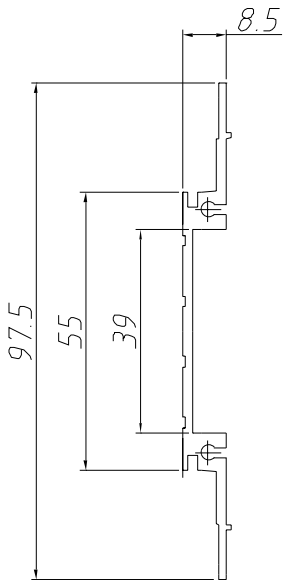

Optional Accessories

Bottom mounting plate

- Material: 1.5mm or 2mm Aluminum sheet
- Choices of two style (style A and style B)
- Fixing onto front rail and rear rail for style A
- Fixing onto two side plate for style B

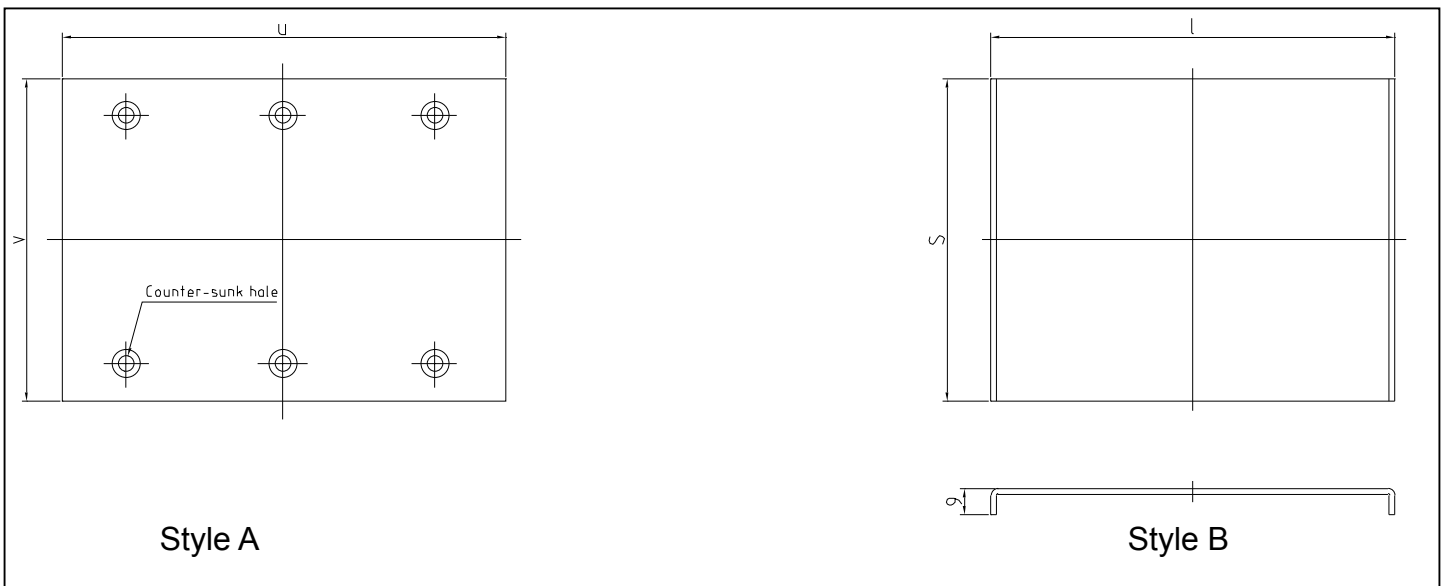
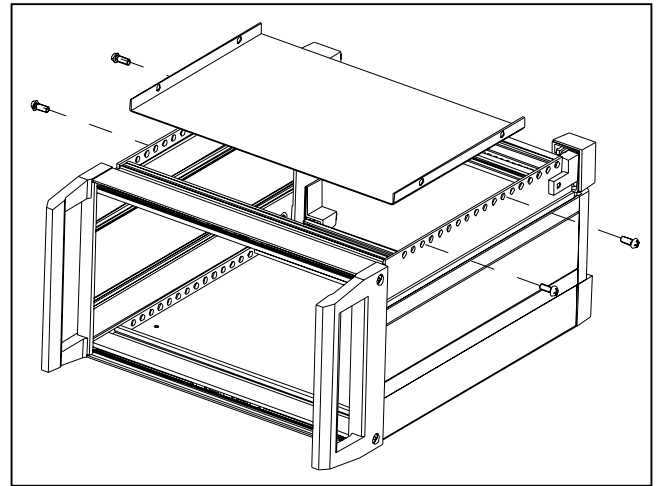

Dimensions chart

Chart 1 (For style A) $u(\text{mm}) \times v(\text{mm})$

Width T	42HP	63HP	84HP
180mm	215×164	322×164	429×164
240mm	215×224	322×224	429×224
300mm	215×284	322×284	429×284
320mm	215×304	322×304	429×304
360mm	215×344	322×344	429×344

Chart 2 (For style B) $l(\text{mm}) \times s(\text{mm})$

Width T	42HP	63HP	84HP
180mm	211×85	318×85	425×85
240mm	211×145	318×145	425×145
300mm	211×205	318×205	425×205
320mm	211×225	318×225	425×225
360mm	211×265	318×265	425×265

Card guide

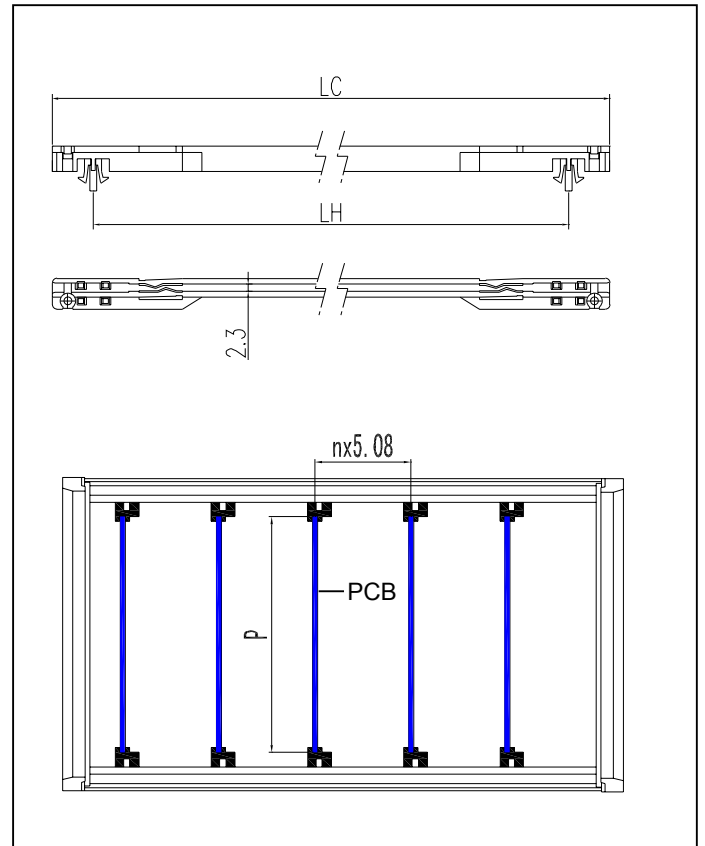
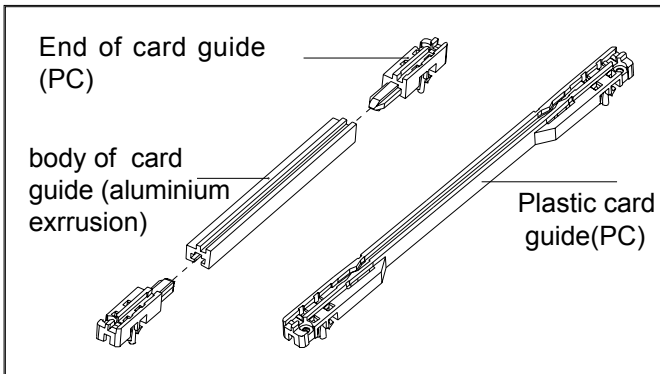
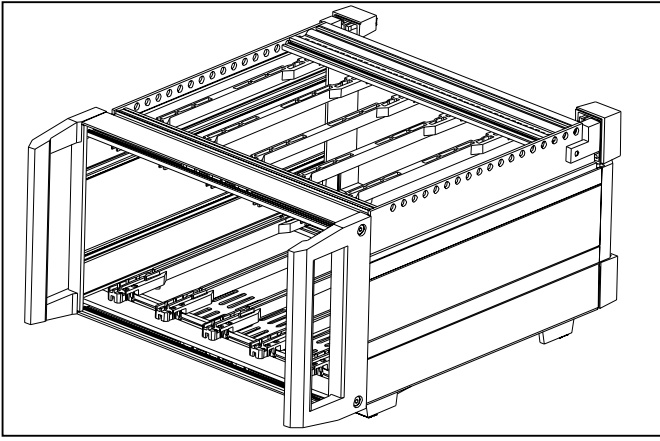

Length of plastic card guide		
LC(mm)	143	210
LH(mm)	123	183

Height of PCB			
H	100	110	120
P(mm)	90	100	110

- Choices of two style of card guide (plastic or alimium extrusion)
- moulded in PC for plastic card guide
- Optional length for aluminum extrusions card guide
- Suitable for 1.6mm to 2.0mm nominal thickness
- Custom colors available

Panel of plug-in unit

- Material :2mm alminium sheet ,Clear anodized
- Quick locks screw into the slide nuts plugged in front rail or rear rail
- With "V" drag
- Optional size of panel, also cut-outs in the panel available

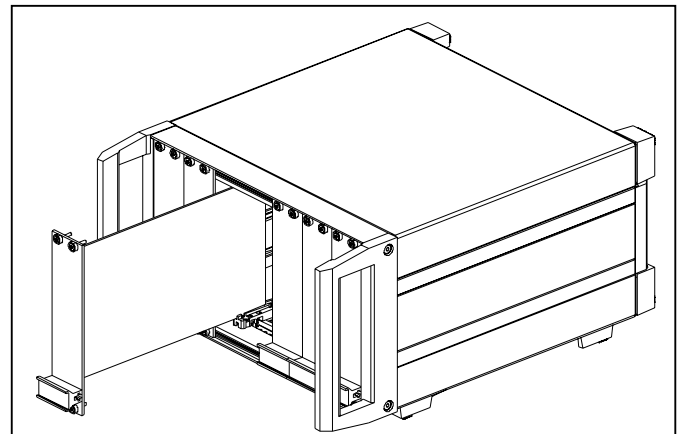

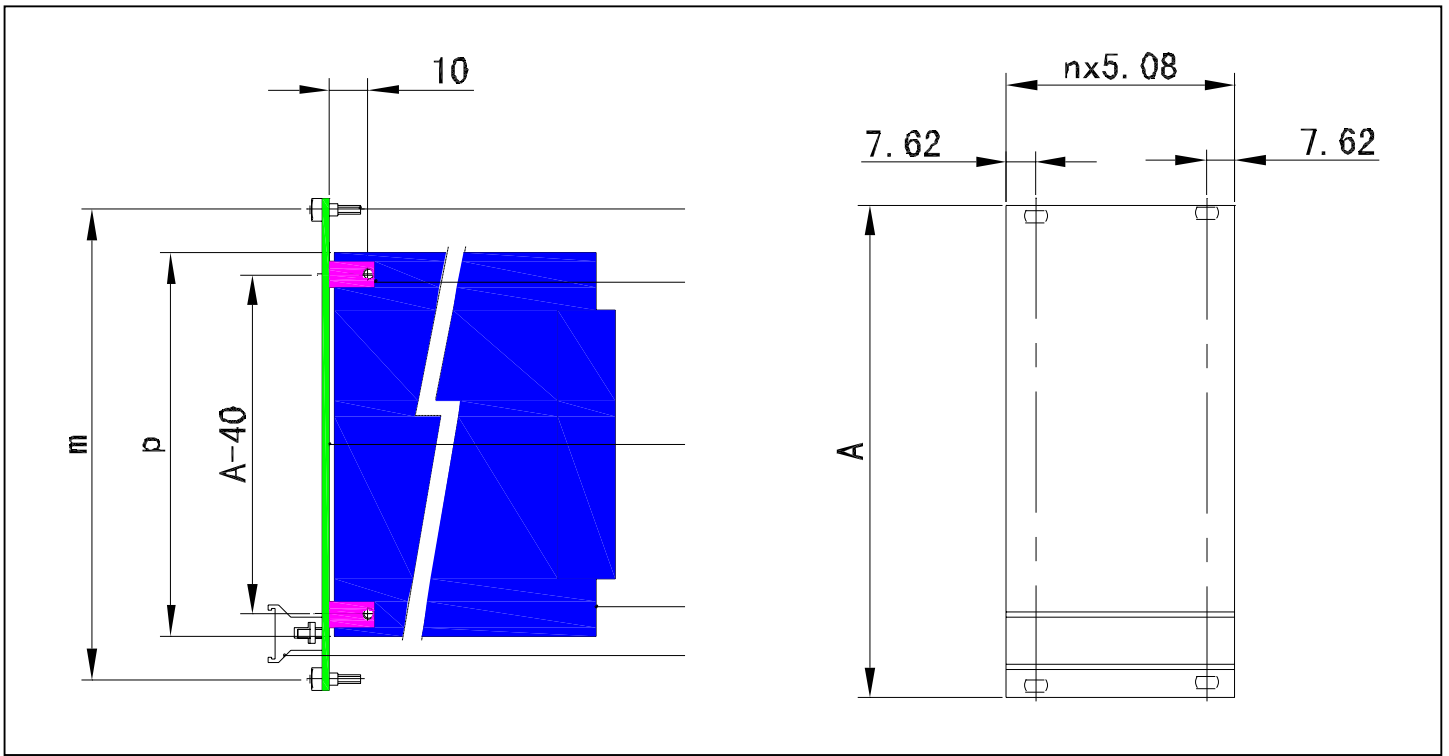

Threaded strip

- Material: Stainless steel
- With threaded holes (pitch of 5.08mm)
- Replacement of slide nuts as standard version
- For mounting front or rear panel

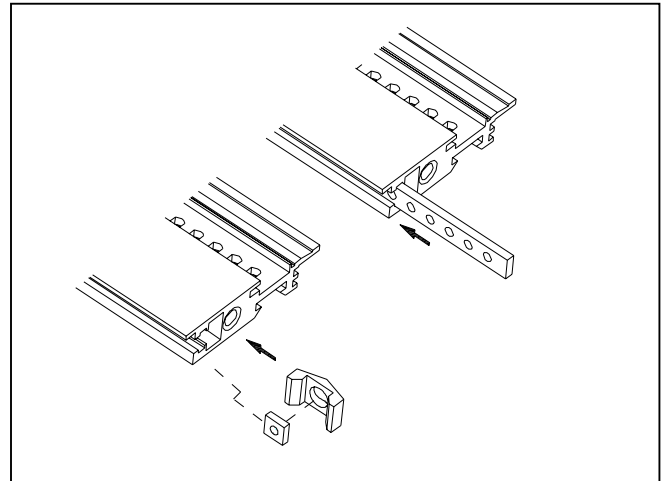

Bottom feet

- Material: PC
- Choices of four style
- Style A as standard version

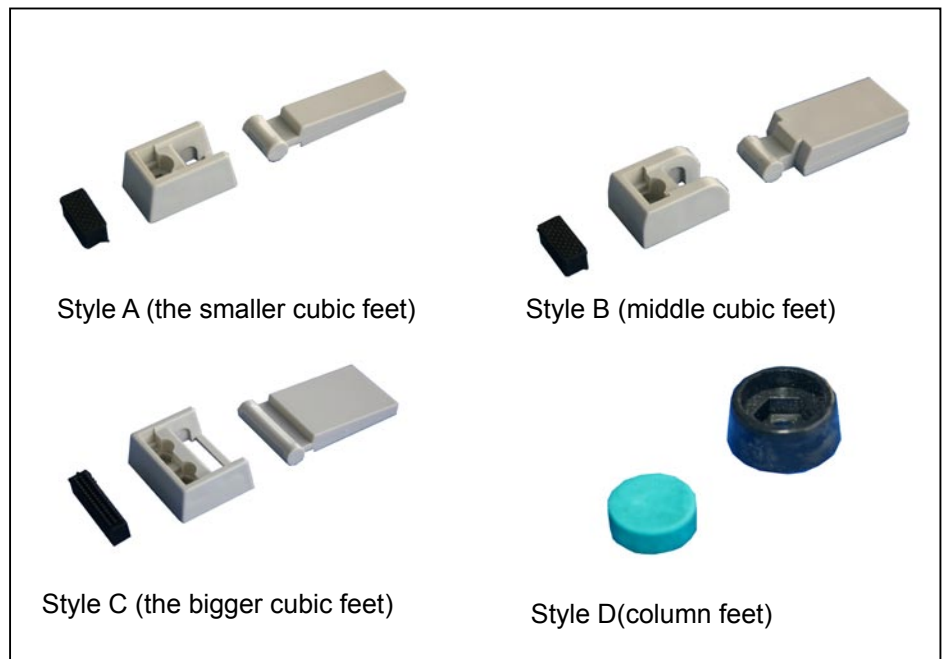
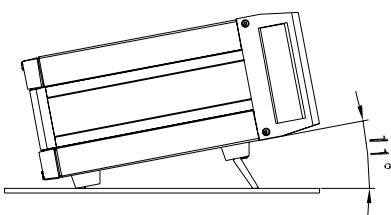

Customization services

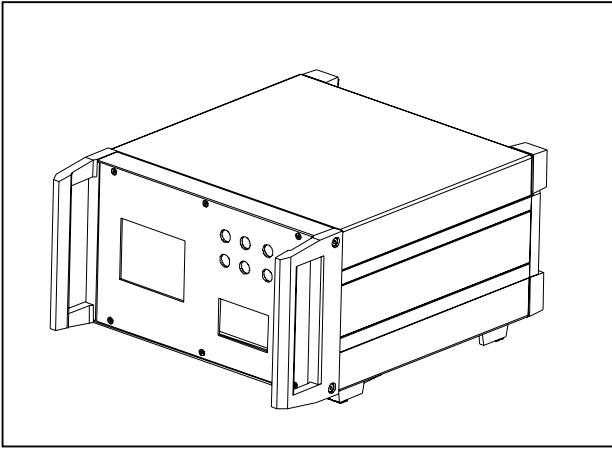

Cut-outs in the front and rear panel

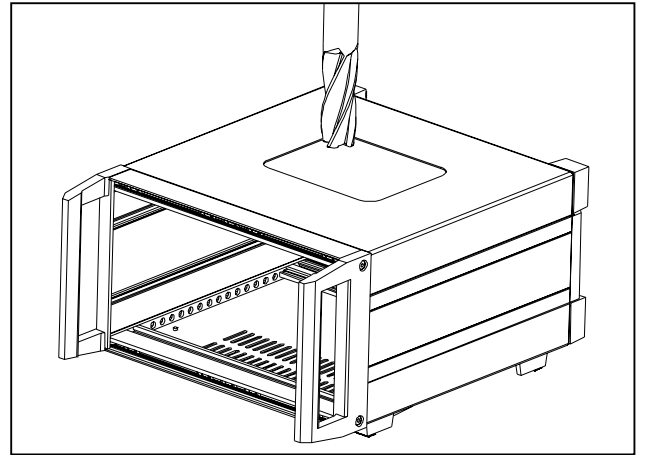

Secondary tooling for top and bottom cover

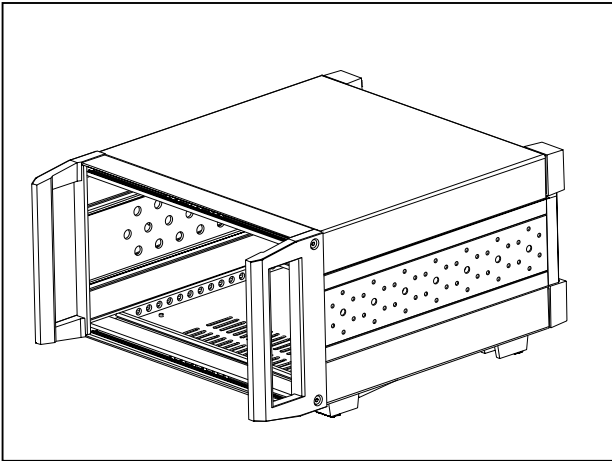

Special vent holes in the side plate

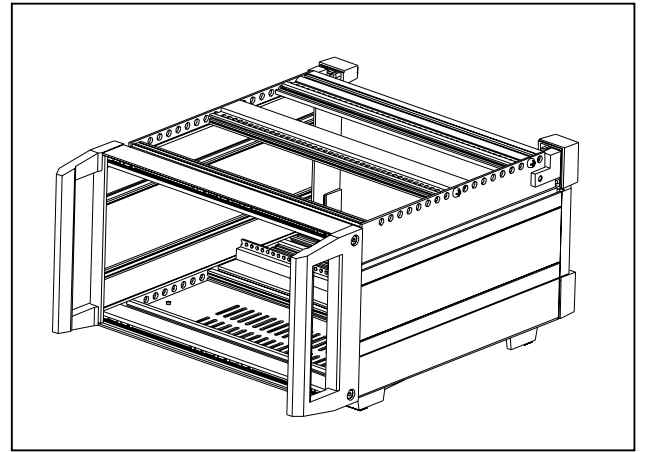

Strengthen enclosure by mounting additional extrusion, which can be used for installation of backplanes

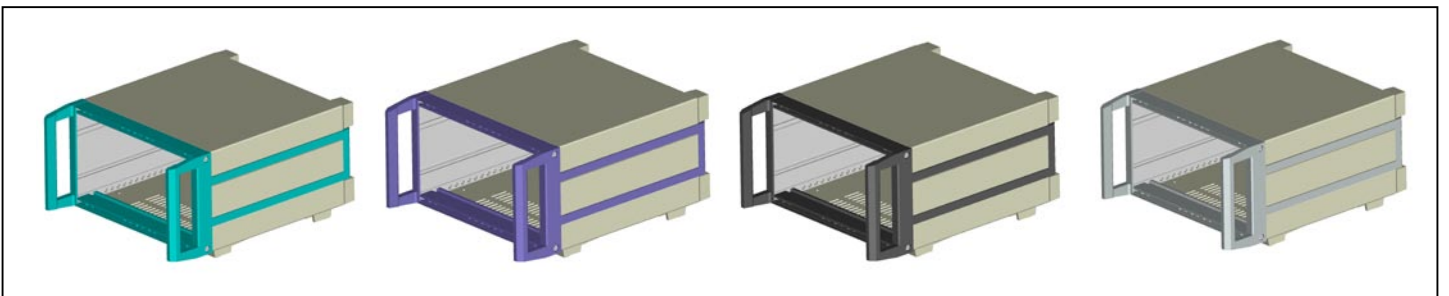

Specify the non-standard colors (you may provide us with the card of your desired color) refer to our web site for the standard version

How to order

It is very simple ordering 01H series enclosures of Changhe
Just pick up the phone and call your local Changhe office (View our web site <http://www.enclosures.com.cn> to get the address of Changhe enclosures, also dial us at 86-574-63028237)

- inform us the model of your enclosure to order
- Inform us the desired overall height(H), overall width(W) and depth(T)
 - * see the chart on page 1 for definitions of H, W and T
- Optional accessories should be separately ordered
- Specify us your desired color of enclosure
 - *see our website to view various of colors configuration
- You should send us the drawing if you require secondary tooling or other cut-outs

Example : Model:01H

case size 110×42HP×300mm

colors: case 2

Accessories: 20 pieces of 210mm plastic card guide



长河机箱

Ningbo Dayang enclosures Co., Ltd.

Economic development zone, changchizhi
Road, Cixi city, Zhejiang province, 315326, China

Tel: 86-574-63028237

Fax: 86-574-63028372

Website: <http://www.enclosures.com.cn>