

02C series



- Aluminum construction
- Multiple cases stacking
- Wide range of case size
- Simple assembly
- Custom colors available
- With handle available
- Special assembly services

Height/Width/Depth Chart

| Model | Exterior size | | | Interior size | | | Panel size | | | |
|---------|----------------|---------------|---------------|---------------|--------------|--------------|------------|-------|--------------|-----|
| | Overall height | Overall width | Overall depth | Inside height | Inside width | Inside depth | Blank size | | Useable size | |
| | H | L | T | h | l | t | B | A | b | a |
| 02C-1-1 | 2U | 280 | 300 | 57 | 236 | 264 | 253.5 | 74.5 | 250 | 70 |
| 02C-1-2 | 3U | 280 | 300 | 102 | 236 | 264 | 253.5 | 119.5 | 250 | 115 |
| 02C-1-3 | 4U | 280 | 300 | 146 | 236 | 264 | 253.5 | 163.5 | 250 | 159 |
| 02C-1-4 | 5U | 280 | 300 | 191 | 236 | 264 | 253.5 | 208.5 | 250 | 204 |
| 02C-2-1 | 2U | 360 | 300 | 57 | 316 | 264 | 333.5 | 74.5 | 330 | 70 |
| 02C-2-2 | 3U | 360 | 300 | 102 | 316 | 264 | 333.5 | 119.5 | 330 | 115 |
| 02C-2-3 | 4U | 360 | 300 | 146 | 316 | 264 | 333.5 | 163.5 | 330 | 159 |
| 02C-2-4 | 5U | 360 | 300 | 191 | 316 | 264 | 333.5 | 208.5 | 330 | 204 |
| 02C-3-1 | 2U | 440 | 350 | 57 | 396 | 314 | 413.5 | 74.5 | 410 | 70 |
| 02C-3-2 | 3U | 440 | 350 | 102 | 396 | 314 | 413.5 | 119.5 | 410 | 115 |
| 02C-3-3 | 4U | 440 | 350 | 146 | 396 | 314 | 413.5 | 163.5 | 410 | 159 |
| 02C3-4 | 5U | 440 | 350 | 191 | 396 | 314 | 413.5 | 208.5 | 410 | 204 |
| 02C-4-1 | 2U | 180 | 250 | 57 | 136 | 214 | 153.5 | 74.5 | 150 | 70 |
| 02C-4-2 | 3U | 180 | 250 | 102 | 136 | 214 | 153.5 | 119.5 | 150 | 115 |
| 02C-4-3 | 4U | 180 | 250 | 146 | 136 | 214 | 153.5 | 163.5 | 150 | 159 |
| 02C-4-4 | 5U | 180 | 250 | 191 | 136 | 214 | 153.5 | 208.5 | 150 | 204 |

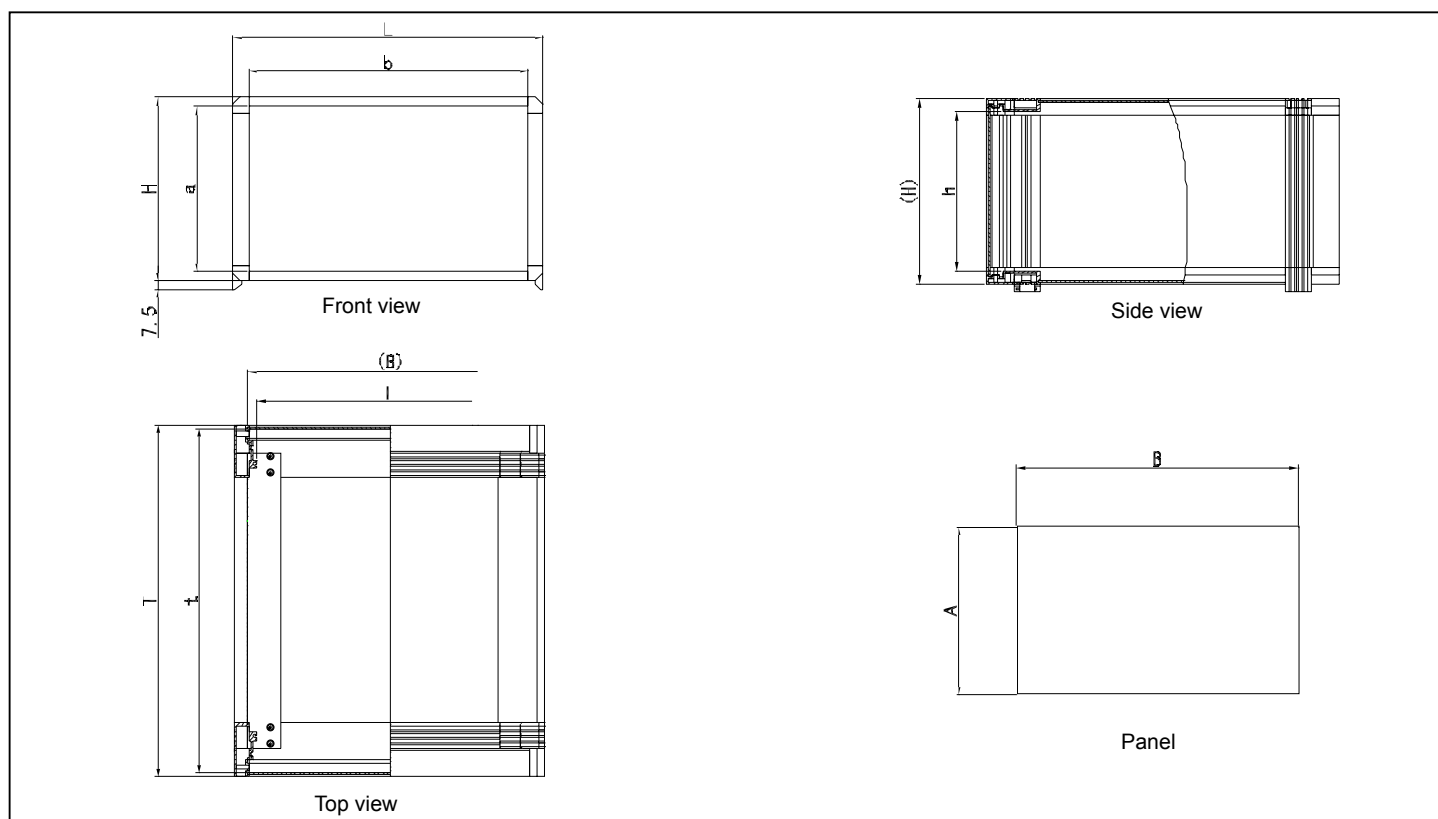

Standard configuration

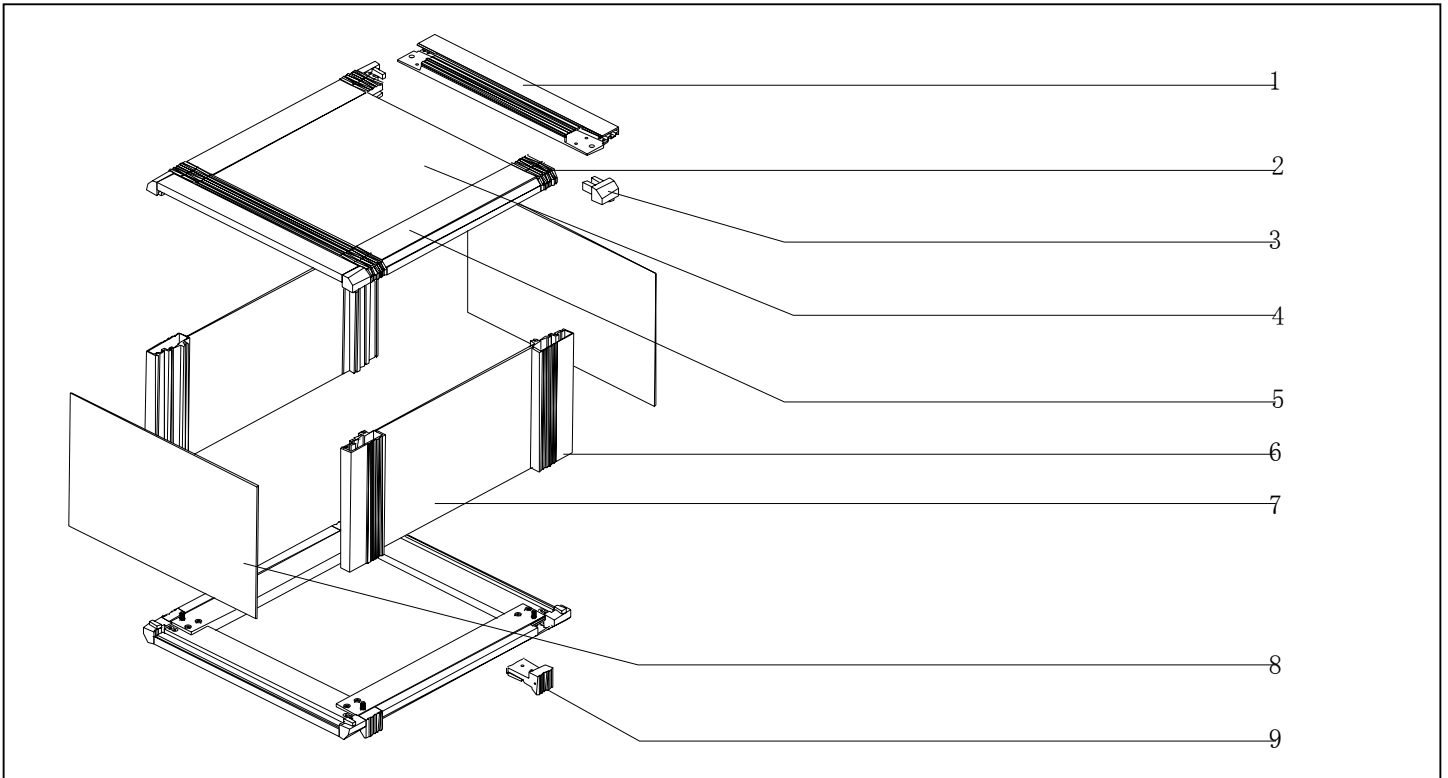

| ITEM | PART | QTY | DESCRIPTION |
|------|-----------------|-----|--------------------------------------|
| 1 | Horizontal rail | 4 | Aluminium extrusion,spary plastic |
| 2 | Screw cover | 4 | Moulded in PC,with mounting screws |
| 3 | Corner | 8 | Diecast aluminum,spary plastic |
| 4 | Cover | 2 | 1.5mm Aluminium sheet, spary plastic |
| 5 | Side rail | 4 | Aluminium extrusion,spary plastic |
| 6 | Mounting angel | 8 | Aluminium extrusion,spary plastic |
| 7 | Side panel | 2 | 1.5mm Aluminium sheet, spary plastic |
| 8 | Panel | 2 | 2mm Aluminium sheet |
| 9 | Case foot | 4 | Moulded in PC,with mounting screws |

Extrusions

Mounting angel

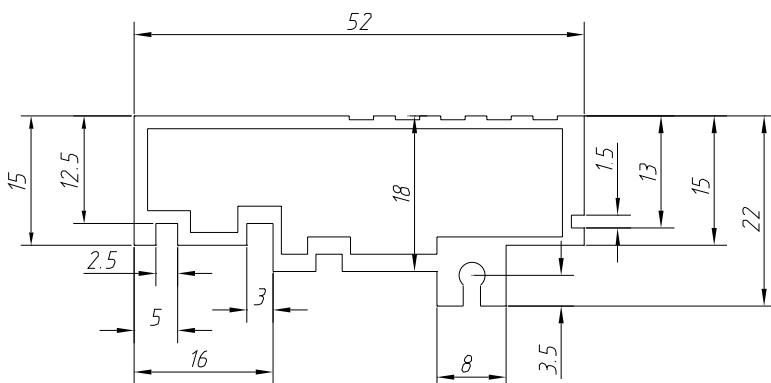

- Material: Aluminum extrusion
- Spary plastic
- Optional height on request

Horizontal rail

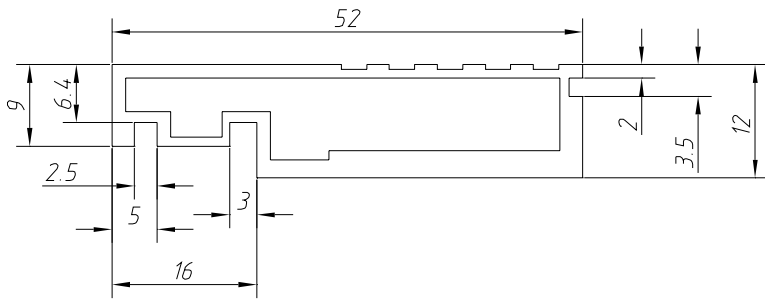

- Material: Aluminum extrusion
- Spary plastic

Side rail

- Material: Aluminum extrusion
- Spary plastic

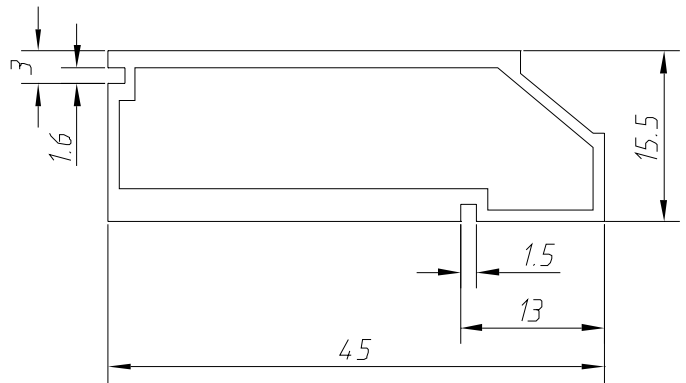

Accessories

Case foot & Screw cover

- Material: PC
- Pre-mounting screws

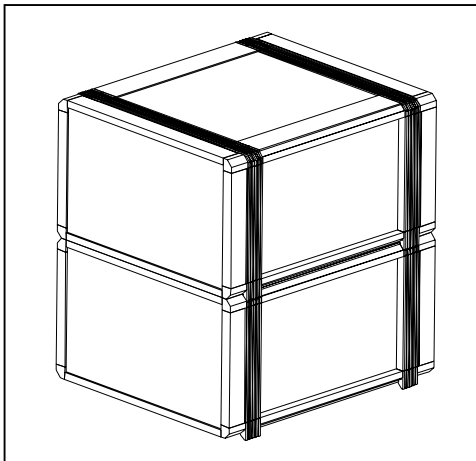

Provide no-slide stability for multiple cases stacking during storage or transport

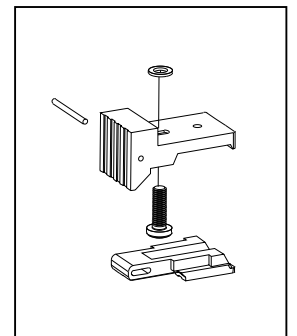
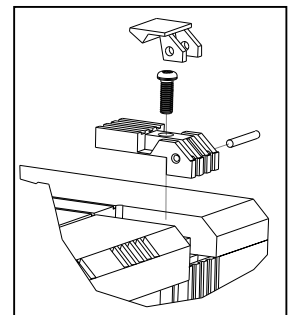

Handle

02C series enclosures are available with three types handle(T3,T4 and T5)

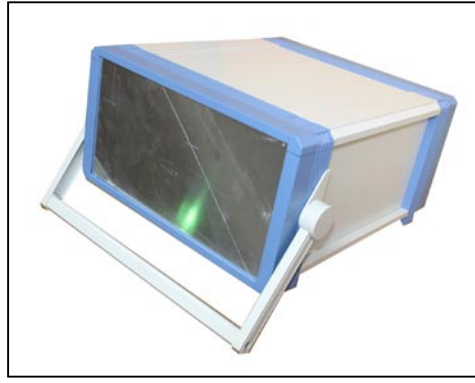

T4



T5

Customization services

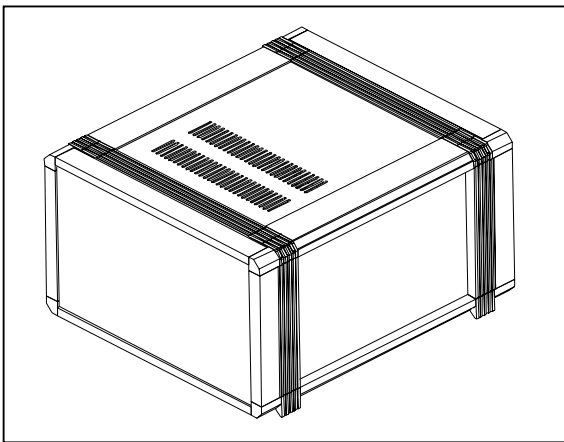

Cut-outs or special vent holes in the top and bottom cover

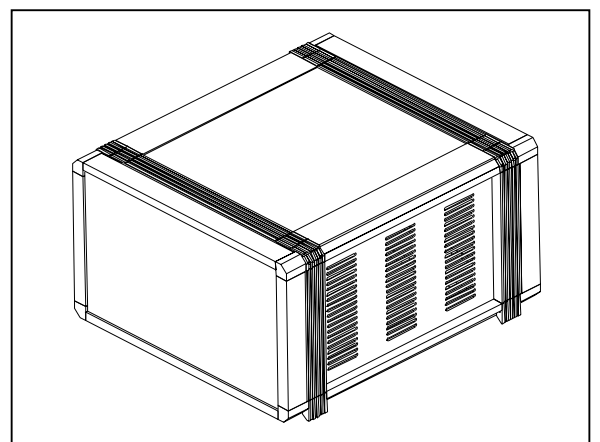

Cut-outs or special vent holes in the side plate

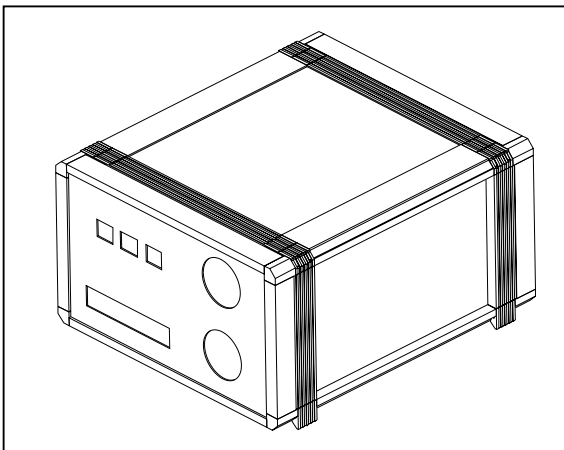

Cut-outs in the front and rear panel

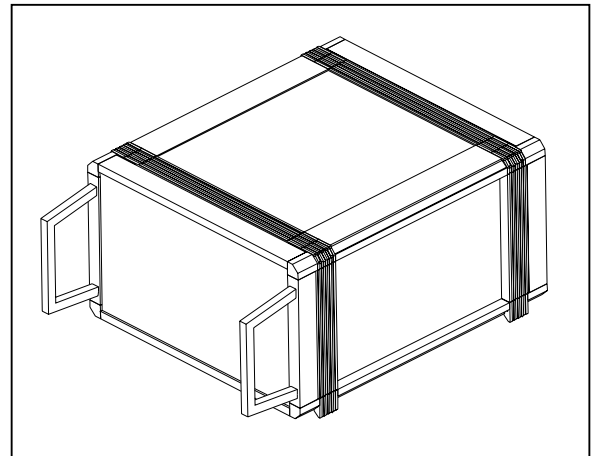

Mounting handle on the front trim for the bigger sizes enclosure

How to order

It is very simple ordering O2C series enclosures of Changhe
Just pick up the phone and call your local Changhe office (View our web site <http://www.enclosures.com.cn> to get the address of Changhe enclosures, also dial us at 86-574-63028237)

- inform us the model of your enclosure to order
- Inform us the desired overall height(H), overall width(W) and depth(T)
* see the chart on page 1 for definitions of H, W and T
- Optional accessories should be separately ordered
- Specify us your desired color of enclosure (see our website to view various of colors configuration)
- Specify the model of handle if you need

- You should send us the drawing if you require secondary tooling or other cut-outs

Example : Model:O2C-1-1
case size 2U×280mm×300mm
colors: case 2
Handle: T5



长河机箱

Ningbo Dayang enclosures Co., Ltd.

Economic development zone, changchizhi
Road, Cixi city, Zhejiang province, 315326, China
Tel: 86-574-63028237
Fax: 86-574-63028372
Website: <http://www.enclosures.com.cn>